

## PRODUCT MODEL



Jabrin

## PRODUCT FEATURES



- Anti-Slip texture
- Seamlessness Surface
- UV-Stable
- Quick and easy to install
- Extra strength
- Hygienic Surface

## CONTACT US



Toll Free:  
**800 82200**

[info@hilalgroup.com](mailto:info@hilalgroup.com)

[www.hilalgroup.com](http://www.hilalgroup.com)

PO BOX 2692, Al Udhaiba  
PC 130 SULTANATE OF OMAN

## PRODUCT DESCRIPTION



Al Hilal Acrylic shower trays and acrylic bathtub represent the highest quality in its segment. They are produced from cast acrylic reinforced with fiberglass.

The smooth seamlessness of acrylic's surface and perfectly balanced color harmony reveal another great feature of Al Hilal acrylic products. Our shower trays and bathtub have sufficient depth, and they are suitable for bathroom renovations.

## PRODUCT SPECIFICATION



Size: (200 X 120 X45 )cm

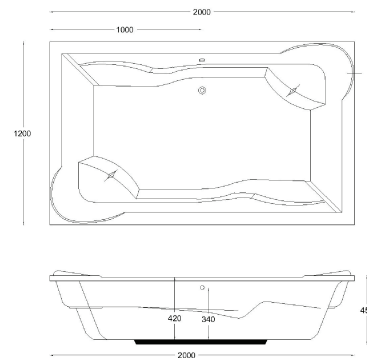

## TECHNICAL DATA



- Acrylic sheet used: Sanitary Grade Cast Acrylic Sheets.
- Sheet type: High gloss %100 PMMA (Poly Methyl Meth Acrylic) Material Sanitary grade cast Acrylic.
- Method OF Manufacturing: Thermoforming Using Vacuum Forming Machine.
- Acrylic sheet thickness: for Bathtubs and Shower Trays - 3MM -5 MM depending on size and shape of the item.
- Base reinforcement: chopped laminated and sealed with GRP reinforcements to give additional strength to the base.